



*Prison Point CSO Facility Improvements
Contract 7462 Award*

September 15, 2021



Prison Point CSO Facility



Main Building



Chemical Building



Prison Point CSO Facility Improvements



Catenary Bar Screens to be Replaced



Replacement of Conveyor System



Prison Point CSO Facility Improvements



Storm Pump Engine to be Replaced



Relocation of Electrical Room



Prison Point CSO Facility Improvements



Dry Weather and Dewatering Pumps
to be Replaced



Generator to be Replaced



Prison Point CSO Facility Improvements



Replacement of Leaking
Chemical Tanks



Replacement of Chemical Building Roof
and Installation of Chemical Tank Access
Hatches



Contract 7462 Award

Contractor	Bid Price
Barletta Heavy Division	\$39,479,000
Walsh Construction Co II	\$40,014,312
<i>Engineer's Estimate</i>	<i>\$42,434,705</i>
Daniel O'Connell's Sons	\$42,650,000



*Nut Island Headworks
Odor Control and HVAC System Improvements
Contract 7548 - Change Order 6*

September 15, 2021



Nut Island Headworks: Odor Control Fan #4 Equipment Pad





Nut Island Headworks: Air Handler VFD Bypass Circuits



VFD Circuit



Bypass Circuit

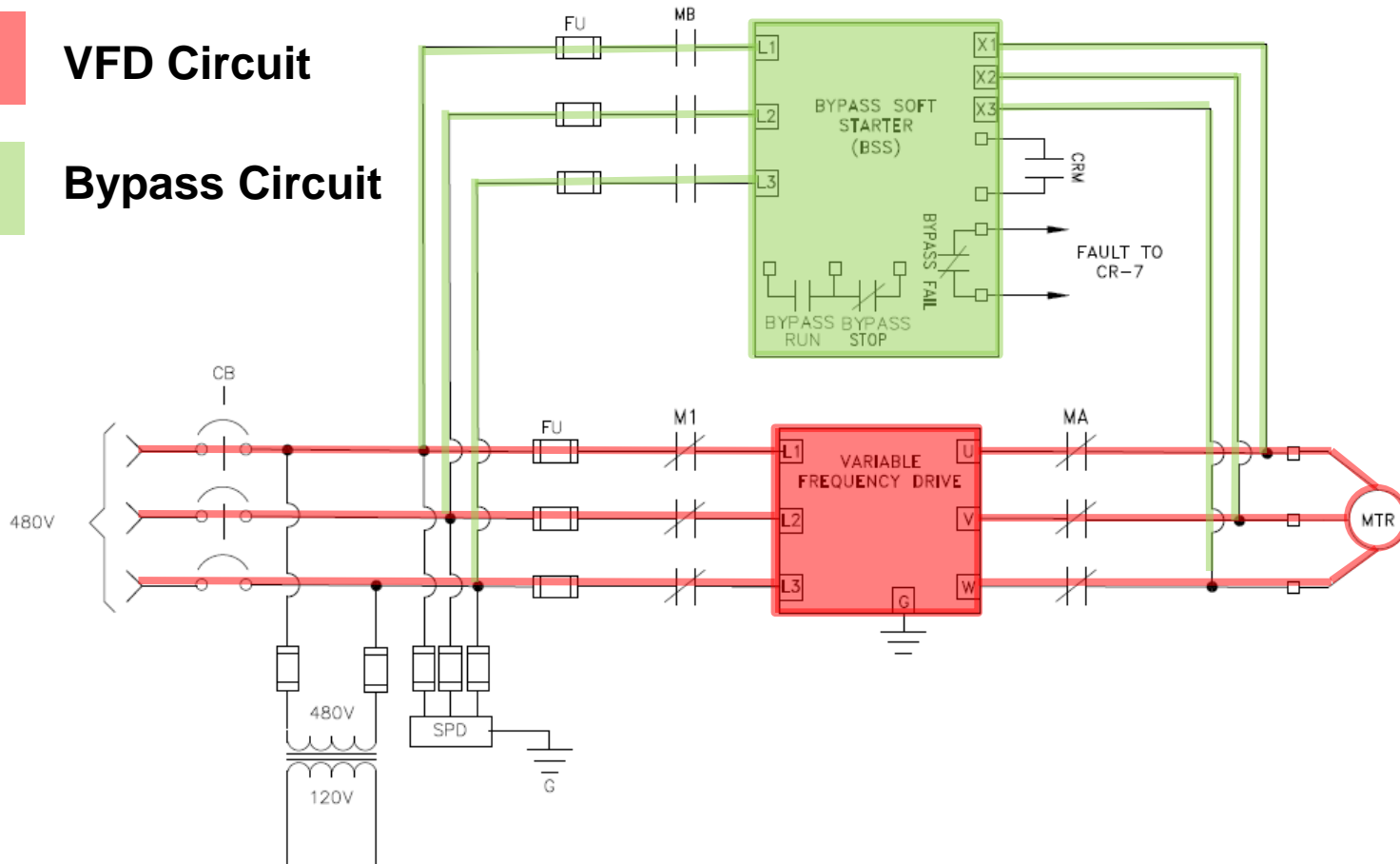



Nut Island Headworks: Odor Control Fan VFD Conflicts





Nut Island Headworks: Odor Control Fan VFD Drip Pans



VFD-3

VFD-4



Nut Island Headworks: Odor Control Fan #4 Startup





Nut Island Headworks: Odor Control Ductwork





Nut Island Headworks: Temporary Carbon Adsorber





Nut Island Headworks: Odor Control Fan #3 Demo





Nut Island Headworks: Underground Fuel Oil Storage Tanks





Nut Island Headworks: Emergency Spillway Gates





*Wastewater Monitoring for COVID-19:
Biobot Analytics, Contract OP-420, Amendment 2*

September 15, 2021



Weekly Average Viral Signal and DPH New Cases by Date

